

**PLAN VIEW**

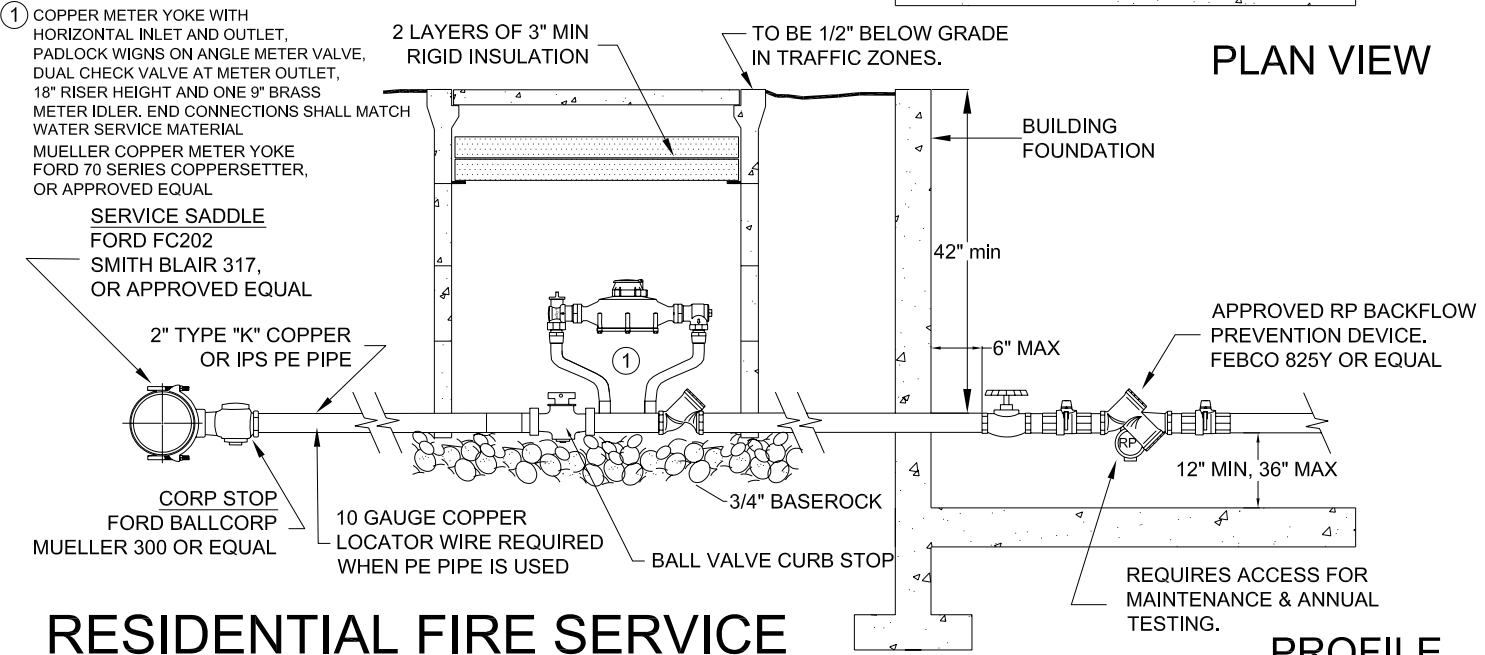

**PROFILE**

**RESIDENTIAL FIRE SERVICE**

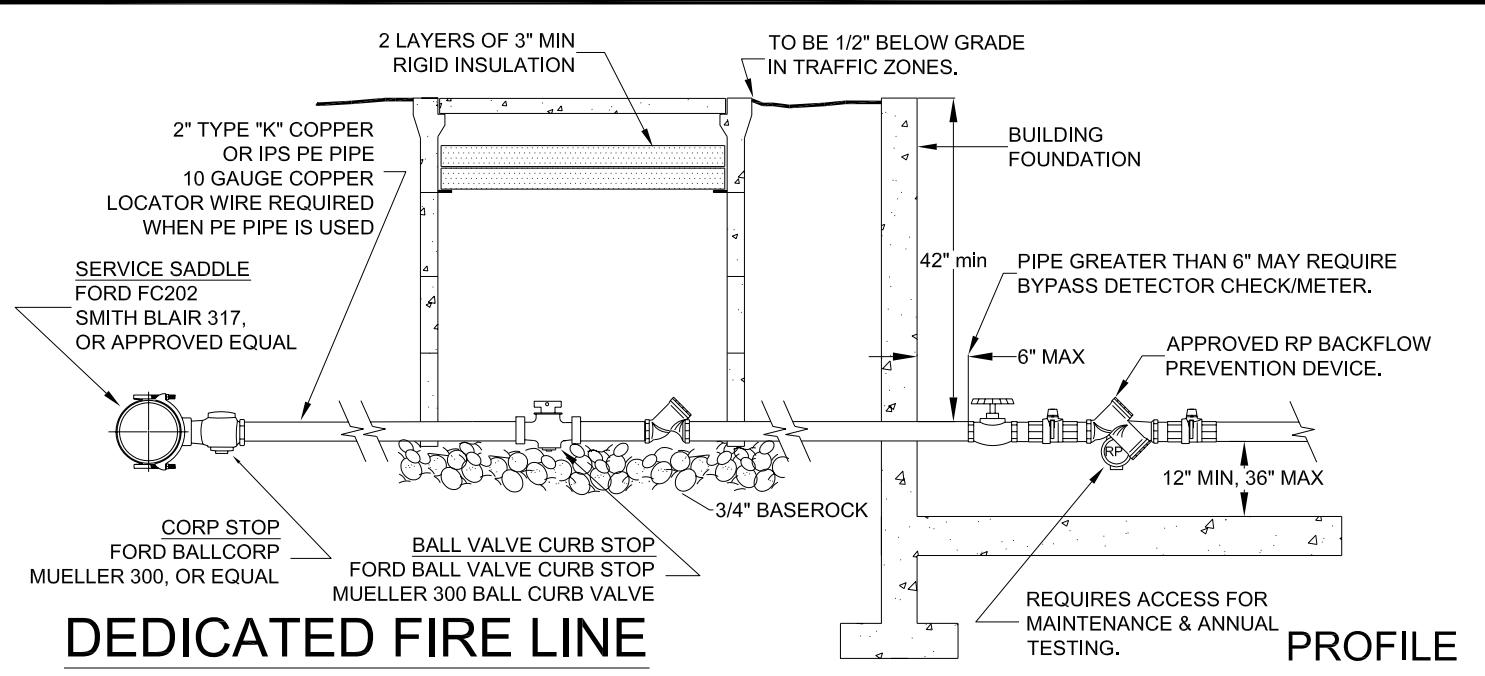

**PROFILE**

**DEDICATED FIRE LINE**